

ARRAY

The ARRAY command allows you to make multiple copies in a **RECTANGULAR** or Circular (**POLAR**) pattern and even on a **PATH**. The maximum limit of copies per array is 100,000. This limit can be changed but should accommodate most users. (Refer to Help menu if you choose to change the limit)

RECTANGULAR ARRAY

This method allows you to make multiple copies of object(s) in a **rectangular pattern**. You specify the number of rows (horizontal), columns (vertical) and the spacing between the rows and columns. The spacing will be equally spaced between copies.

Spacing is sometimes tricky to understand. **Read this carefully.** The spacing is the distance from a specific location on the original to that same location on the future copy. It is not just the space in between the two. Refer to the example below.

To use the rectangular array command you will select the object(s), specify how many rows and columns desired and the spacing for the rows and the columns. **Refer to step by step instructions on page 13-3.**

Example of Rectangular Array:

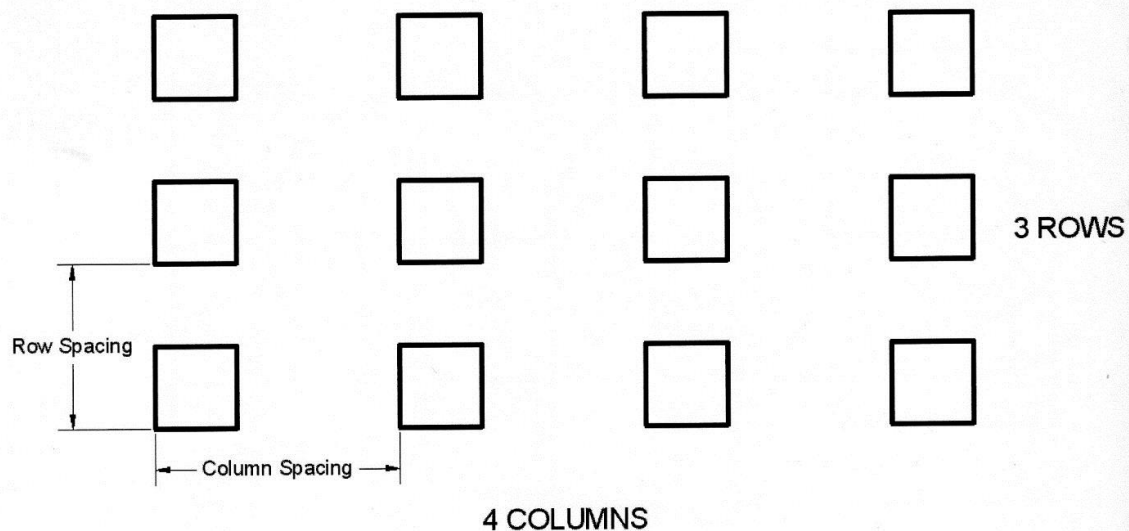

ARRAY....continued

How to create a RECTANGULAR ARRAY

1. Draw a 1" square Rectangle.
2. Select the **ARRAY** command using one of the following:

Ribbon = Home tab / Modify panel / Array ▼
or
Keyboard = Array <enter>

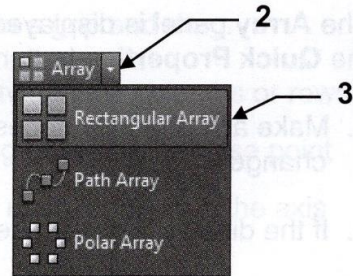

3. Select **Rectangular Array**.
4. Select Objects: **Select the Object to be Arrayed.**
5. Select Objects: **Select more objects or <enter> to stop**

The **Array Creation** tab appears and a 3 x 4 default grid array of the object selected.

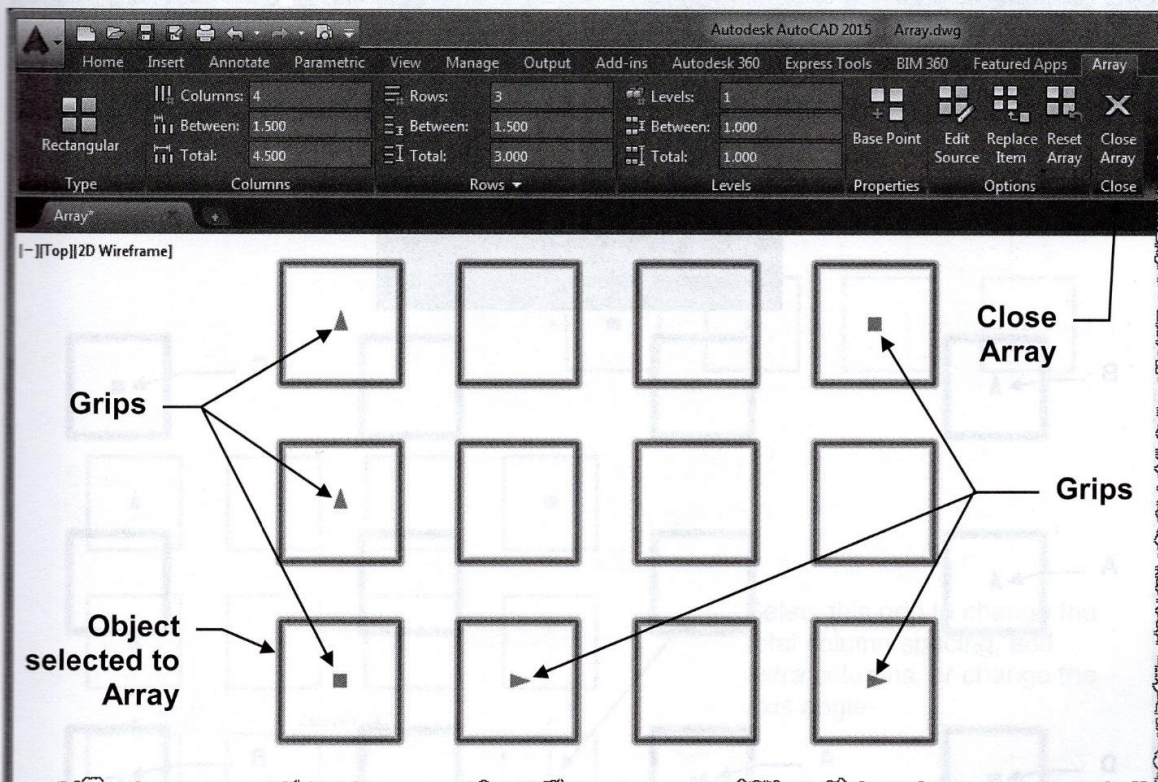

6. Make any changes necessary in the **Array Creation** tab, then press **<enter>** to display any changes.
7. If the display is correct select **Close Array**.

ARRAY....continued

How to edit a RECTANGULAR ARRAY

1. Select the Array to edit.

The **Array** panel is displayed. (The **Quick Properties** will also be displayed if you have the **Quick Properties** button ON in the Status bar.)

2. Make any changes necessary in the **Array** tab, then press **<enter>** to display any changes.

3. If the display is correct select **Close Array**.

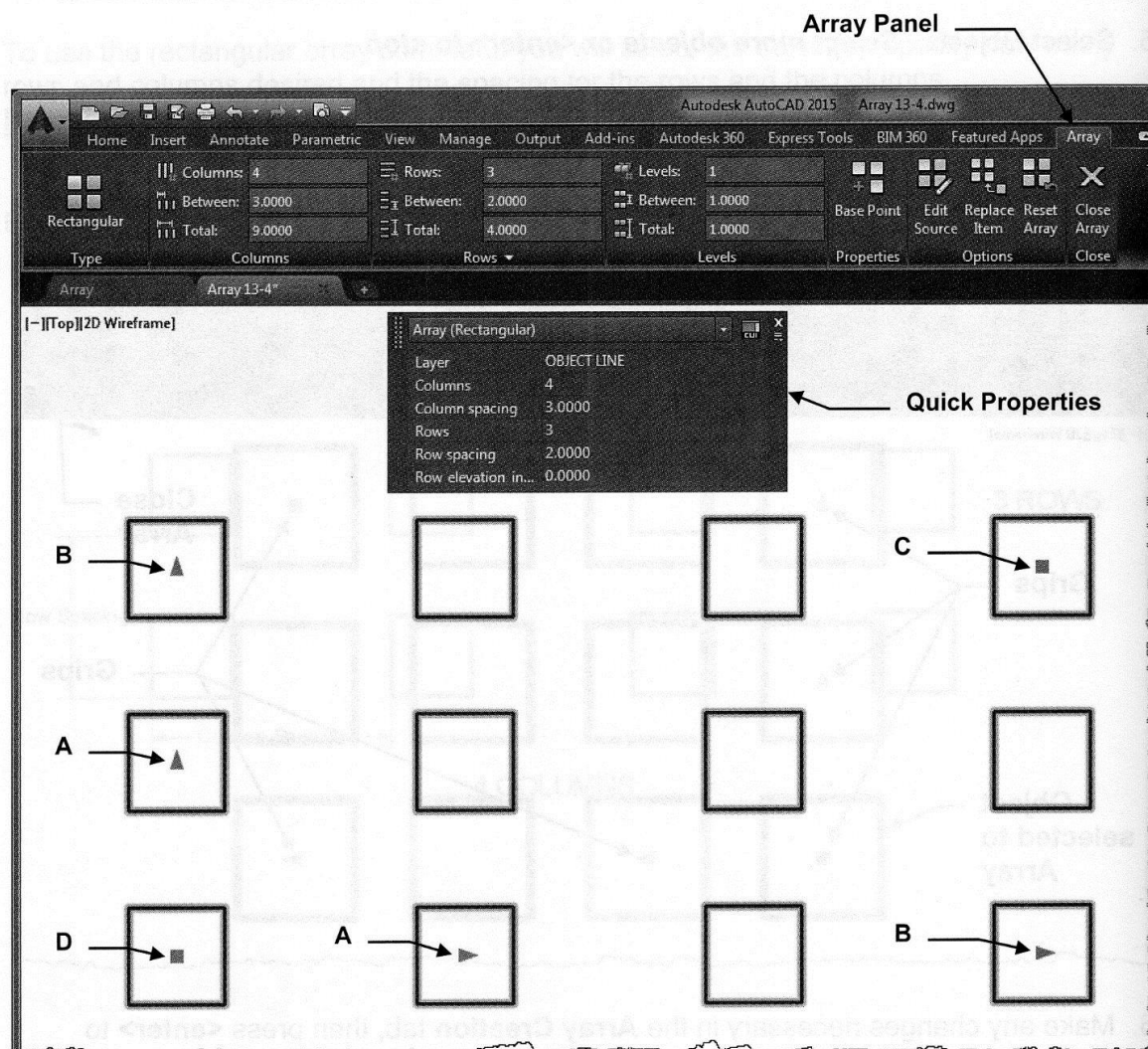









Continued on the next page...

ARRAY....continued

How to edit a RECTANGULAR ARRAY

Using Grips to edit.

You may also use the Grips to edit the spacing. Just click on a grip and drag.

- A. The first  or  allows you to change the spacing between the columns or rows.
- B. The last  or  allows you to change the total spacing between the base point and the last  or  and also to add extra columns or rows, or change the axis angle.
- C. The  allows you to change the total row and column spacing simultaneously, and also to add extra columns and rows simultaneously.
- D. Use the Base Point grip  to **MOVE** the entire Array.

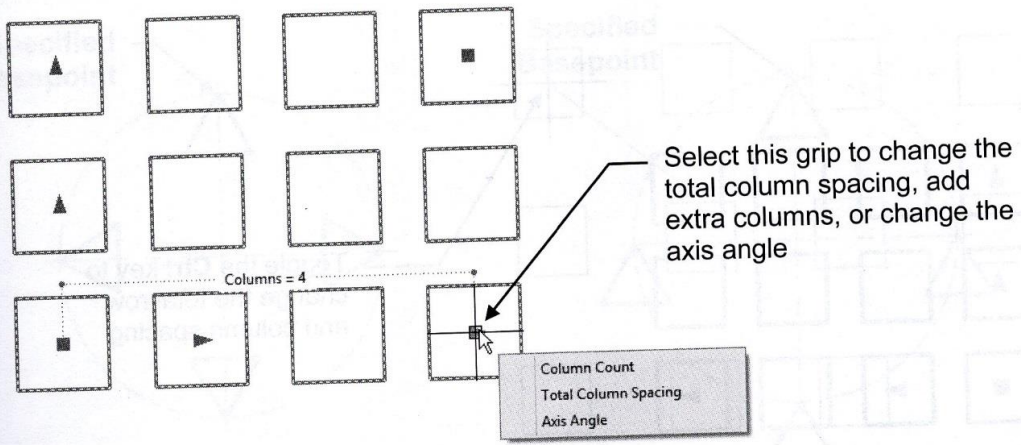
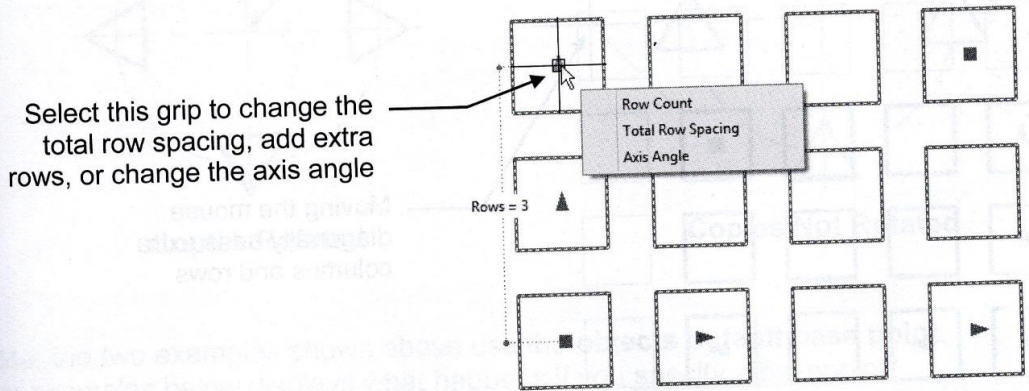

Continued on the next page.

ARRAY....continued

How to edit a RECTANGULAR ARRAY

Using Grips to edit.

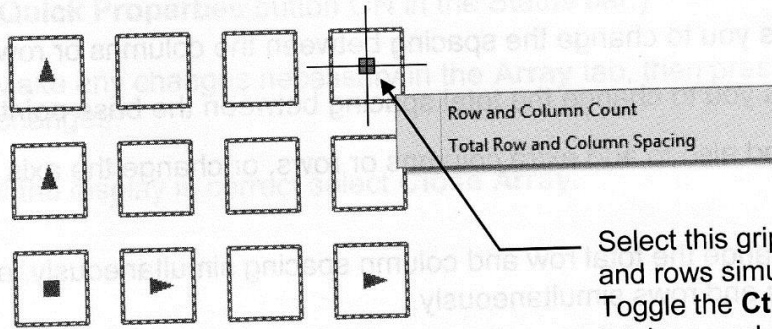

Select this grip to add columns and rows simultaneously. Toggle the **Ctrl** key to change the total row and column spacing

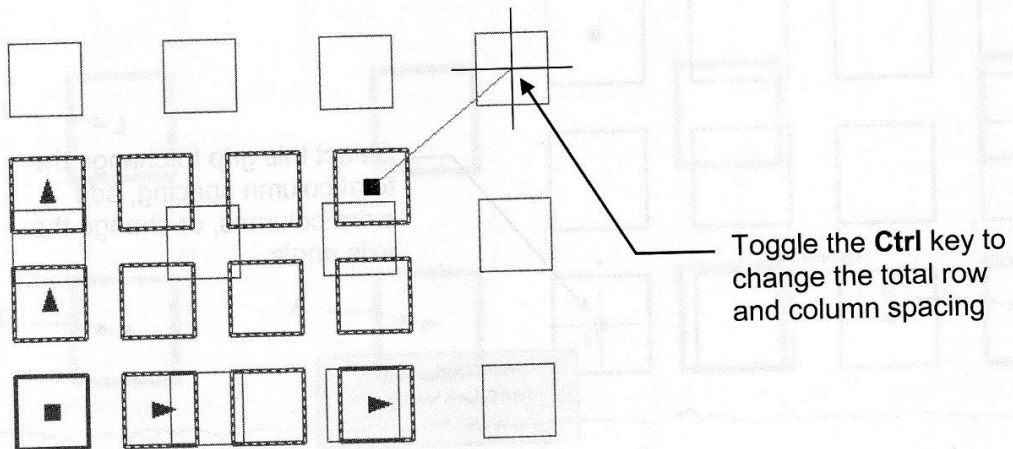
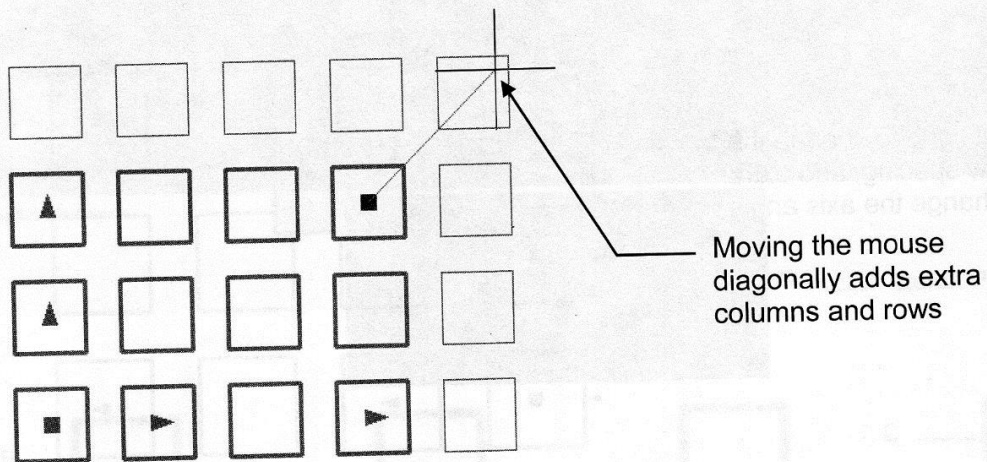

ARRAY....continued

POLAR ARRAY

This method allows you to make multiple copies in a circular pattern. You specify the total number of copies to fill a specific Angle or specify the angle between each copy and angle to fill.

To use the polar array command you select the object(s) to array, specify the center of the array, specify the number of copies or the angle between the copies, the angle to fill and if you would like the copies to rotate as they are copied.

Example of a Polar Array

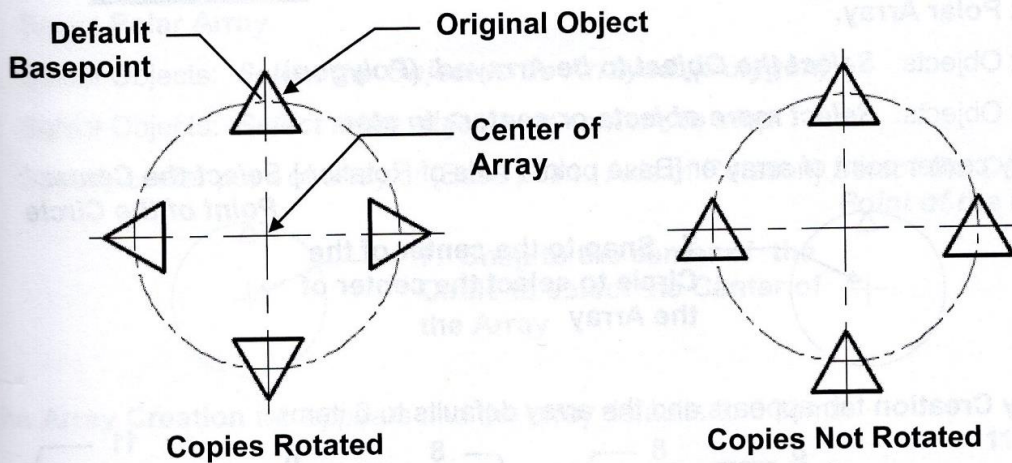

Note: the two examples shown above use the **objects default base point**. The examples below displays what happens if you specify a basepoint.

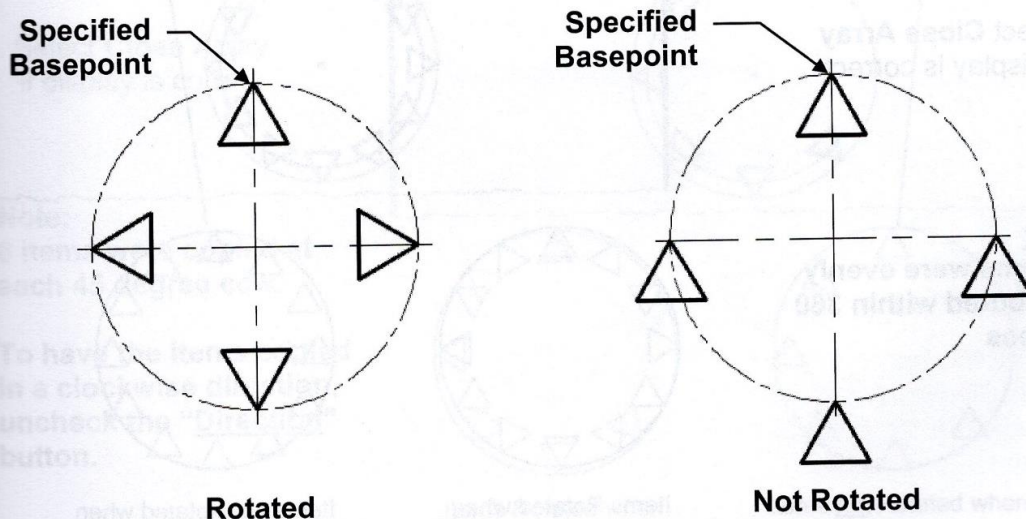

ARRAY....continued

How to create a POLAR ARRAY Using "Number of Items".

1. Draw a 3" Radius circle.
2. Add a .50 Radius 3 sided Polygon and place as shown.
3. Select the **ARRAY** command using one of the following:
Ribbon = Home tab / Modify panel / Array ▼
or
Keyboard = Array <enter>

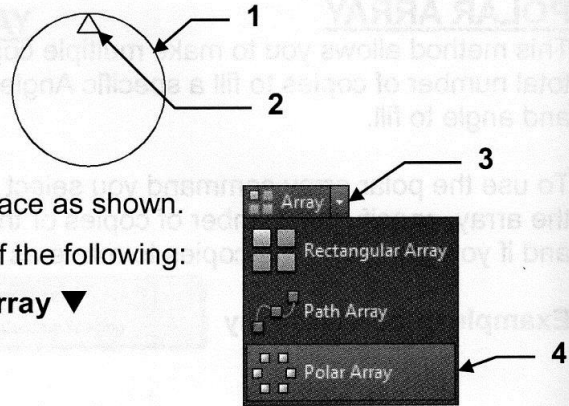

4. Select **Polar Array**.
5. Select Objects: **Select the Object to be Arrayed. (Polygon)**
6. Select Objects: **Select more objects or <enter> to stop**
7. Specify center point of array or [Base point / Axis of Rotation] **Select the Center Point of the Circle**

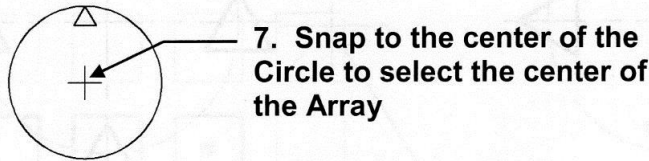

The **Array Creation** tab appears and the array defaults to 6 items.

8. Enter items: **12**
9. Enter Fill: **360**
10. Press <enter> to display the selections.
11. Select **Close Array** if display is correct

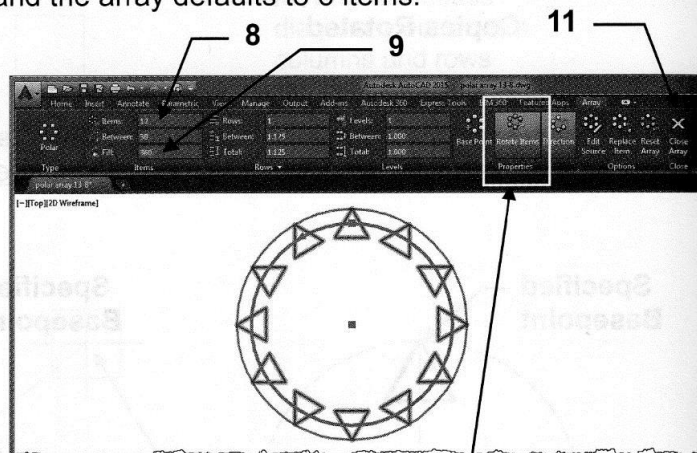

Note:
12 items were evenly distributed within 360 degrees

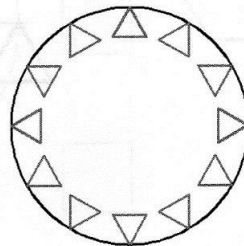

Items Rotated when Polar Arrayed

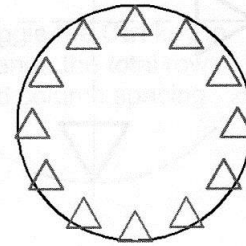

Items not Rotated when Polar Arrayed (Uncheck)

ARRAY....continued

How to create a POLAR ARRAY Using "Angle Between".

1. Draw a 3" Radius circle.
2. Add a .50 Radius 3 sided Polygon and place as shown.
3. Select the **ARRAY** command using one of the following:

Ribbon = Home tab / Modify panel / Array ▼
or
Keyboard = Array <enter>

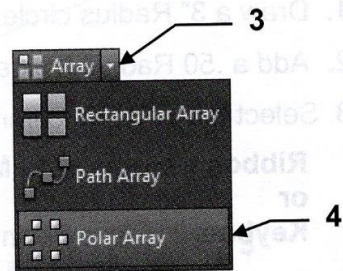

4. Select **Polar Array**.
5. Select Objects: **Select the Object to be Arrayed. (Polygon)**
6. Select Objects: **Select more objects or <enter> to stop**
7. Specify center point of array or [Base point / Axis of Rotation] **Select the Center Point of the Circle**

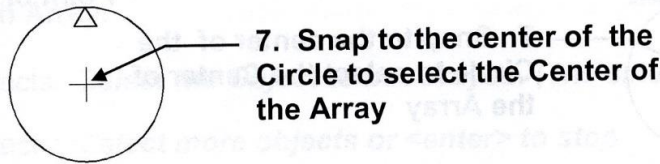

The **Array Creation** tab appears and the array defaults to 6 items.

8. Enter items: **6**
9. Enter Between: **45**
10. Press <enter> to display the selections.
11. Select **Close Array** if display is correct

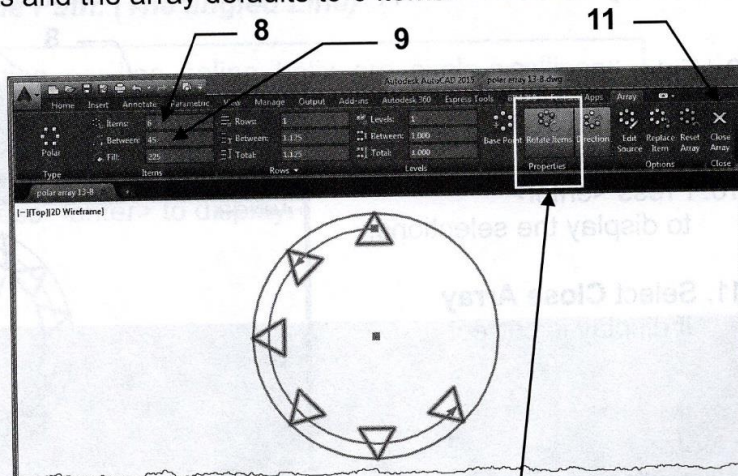

Note:
6 items were copied at each 45 degree ccw.

To have the items copied in a clockwise direction, uncheck the "Direction" button.

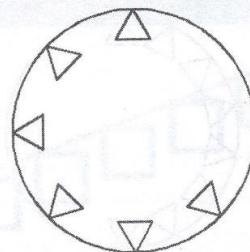

Items Rotated when Polar Arrayed

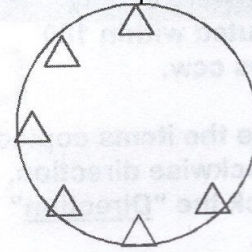

Items not Rotated when Polar Arrayed (Uncheck)

ARRAY....continued

How to create a POLAR ARRAY Using "Fill Angle".

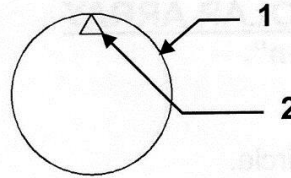

1. Draw a 3" Radius circle.
2. Add a .50 Radius 3 sided Polygon and place as shown.
3. Select the **ARRAY** command using one of the following:

Ribbon = Home tab / Modify panel / Array ▼
or
Keyboard = Array <enter>

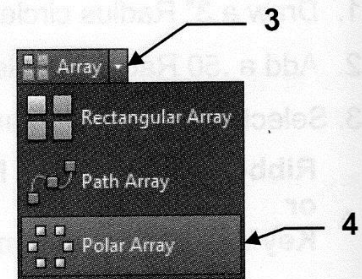

4. Select **Polar Array**.
5. Select Objects: **Select the Object to be Arrayed. (Polygon)**
6. Select Objects: **Select more objects or <enter> to stop**
7. Specify center point of array or [Base point / Axis of Rotation] **Select the Center Point of the Circle**

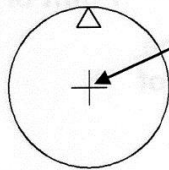

7. Snap to the center of the Circle to select the Center of the Array

The **Array Creation** tab appears and the array defaults to 6 items.

8. Enter items: **8**
9. Enter Fill: **180**
10. Press <enter> to display the selections.
11. Select **Close Array** if display is correct

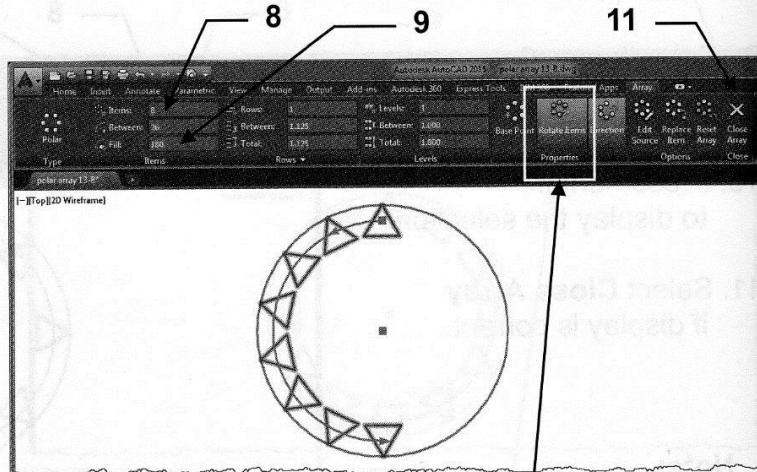

Note:
8 items were evenly distributed within 180 degrees ccw.

To have the items copied in a clockwise direction, uncheck the "Direction" button.

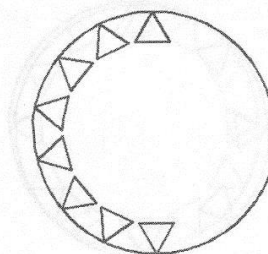

Items Rotated when Polar Arrayed

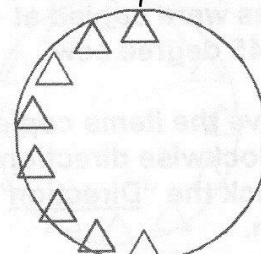

Items not Rotated when Polar Arrayed (Uncheck)

ARRAY....continued

How to create a PATH ARRAY

1. Draw a Line 6" long at 20 degrees.
2. Add a 0.500" x 0.500" Rectangle as shown.

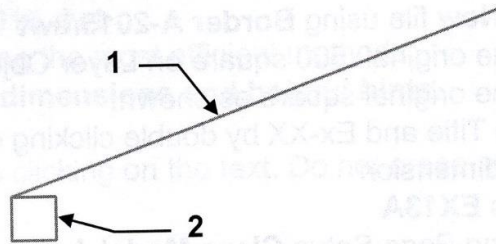

3. Select the **ARRAY** command using one of the following:

Ribbon = Home tab / Modify panel / Array ▼
or
Keyboard = Array <enter>

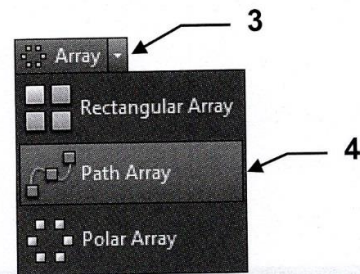

4. Select **Path Array**.
5. Select Objects: **Select the Object to be Arrayed. (The small Rectangle)**
6. Select Objects: **Select more objects or <enter> to stop**
7. Select Path Curve: **Select the Path. (The angled Line)**

Note: The Path can be a line, polyline, spline, helix, arc, circle or ellipse.

The **Array Creation** tab appears and the array defaults to 9 items.

8. Make any alterations and press <enter> to display.
9. If correct select **Close Array**

